

Instruction Sheet

Follow these instructions to install solid shortening heater kit 8263780 in FQG30T Touch Fryers.

1. Disconnect power cord from power source before removing any panels from the equipment. Remove the fryer from the hood to gain access to the front and back of the unit.
2. Remove lower back. It is recommended to also remove doors and cabinet sides for ease of access.
3. Locate and remove filter control (FIB) box and carefully disconnect wiring from rear of the box (Figures 1 & 2).
4. Disconnect flex line from ATO pump at the return manifold and replace with plug (Figures 3 & 4).
5. Remove nuts retaining ATO pump mount and remove the pump assembly from the system. (Figure 5).
6. Re-connect the filter control box (FIB) removed in step 3 and re-connect all the wires (see Figure 1 & 2).

Continued on the next page.

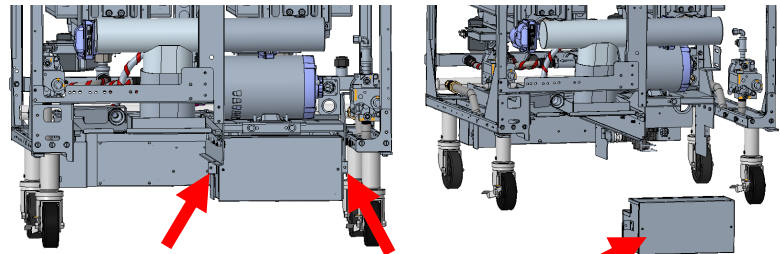

Fig 1

Fig 2

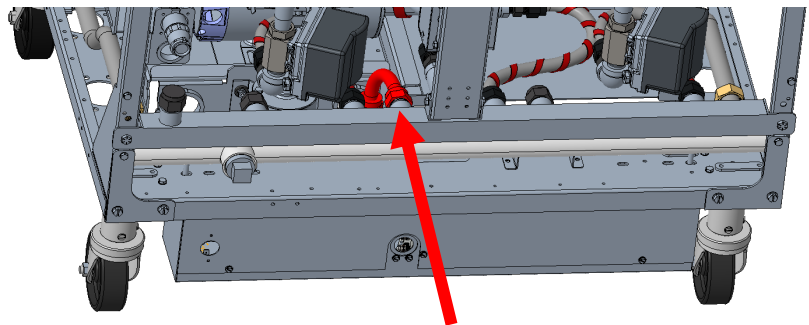

Fig 3

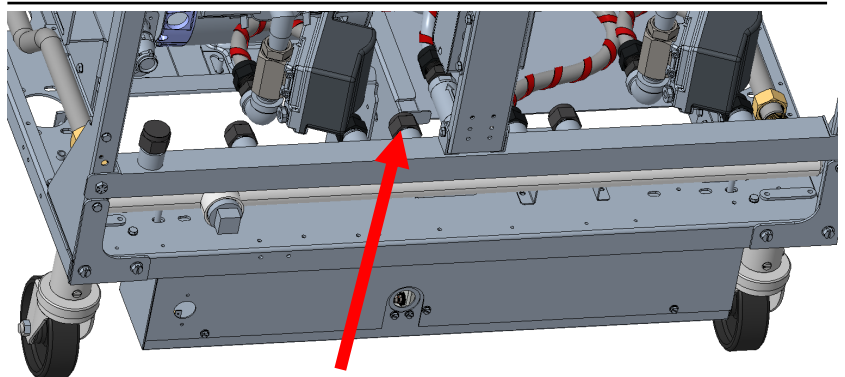

Fig 4

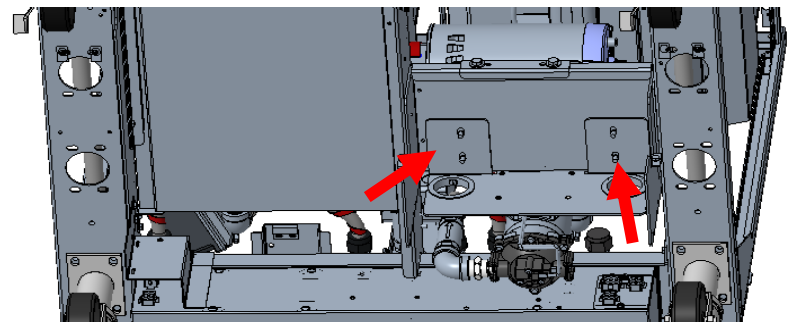

Fig 5

Continued from page 1

6. Mount both handy boxes back to back in location shown on rear center vertical support (Figure 6).
7. Using one of the 36-inch heaters from the kit and a length of foil tape, attach the heater to bottom side of manifold wrapping extra length around the ends and over the top securing in place with foil tape. (Figure 7).
8. Wrap all the flex lines and the filter pump using foil tape to retain tightly around oil line. While it may not be shown well in illustration, **ALL** check valves and return valve bodies must also be covered in heater strips (Figures 8 & 9).

Continued on the next page.

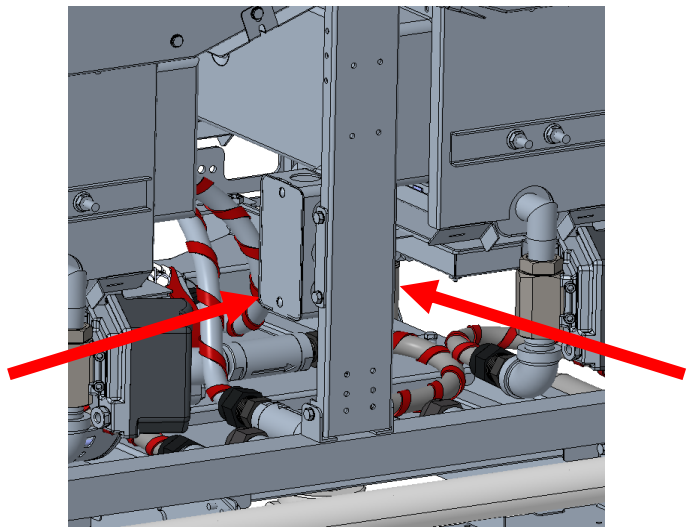

Fig 6

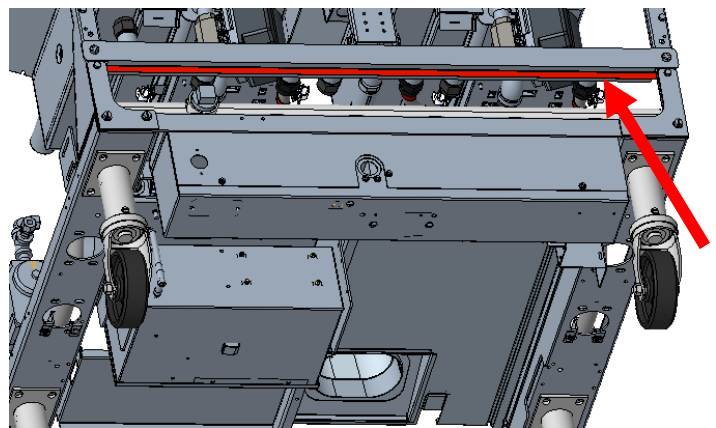

Fig 7

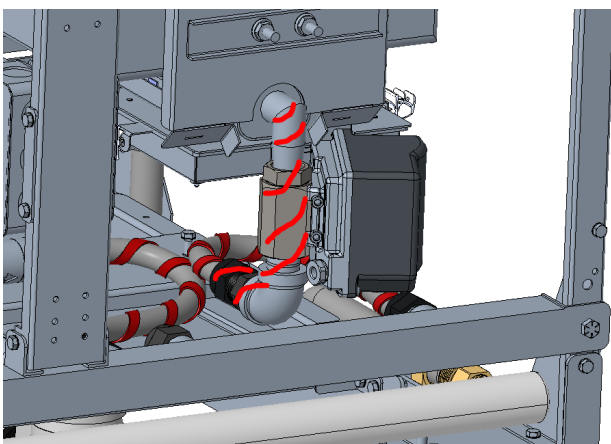

Fig 9

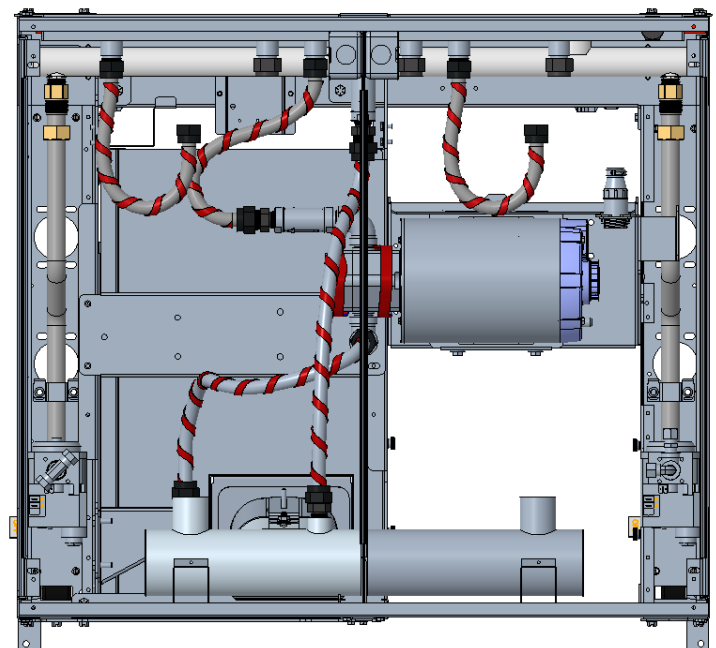

Fig 8

Continued from page 2

9. Remove the JIB cradle if it is already installed. Reattach the factory shipping brace if it was removed to remove the filter box and pump. (Figure 10).

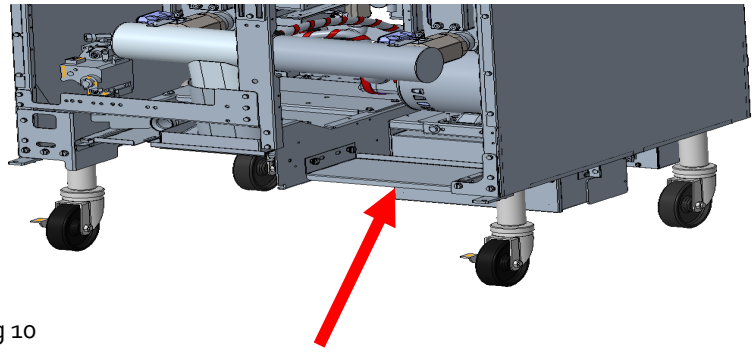

Fig 10

10. Route all wires toward handy boxes and cover wires in sleeving.

11. Locate the plug with line voltage wires to the filter pump motor on the front of the transformer box (Figure 11).

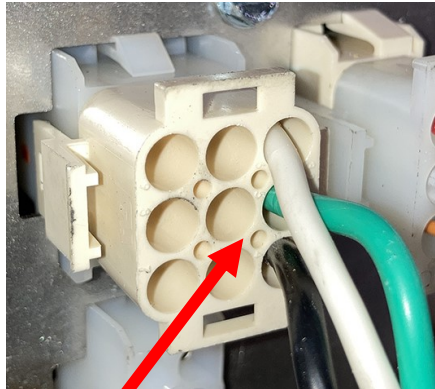

Fig 11

12. Disconnect the plug (Figure 11A).

13. Insert the pins of the provided harness into pin positions 8 & 9 (Figure 11B). Reconnect plug.

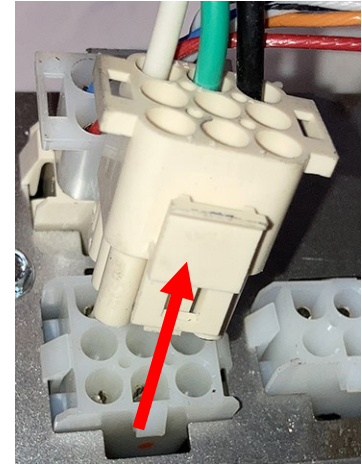

Fig 11A

14. Route the wires to the pump to the rear of the fryer. They will be reattached to power later in the handy box (Figure 12), when the new heater tape is attached.

15. Use Wago terminal blocks to wire up heaters according to diagram on the last page.

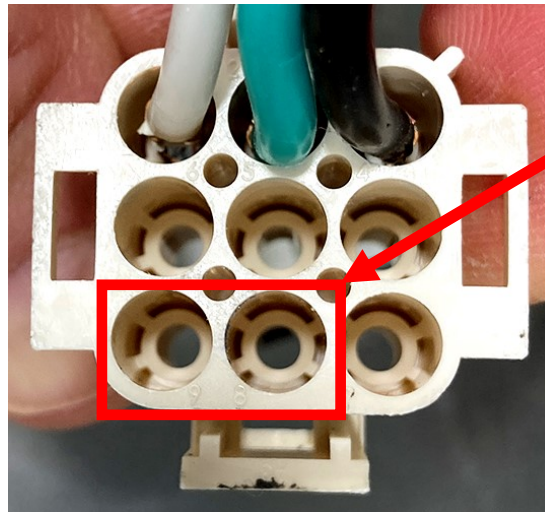

Fig 11B

16. Ensure the wire connections are positioned to exit the wrapping near the left junction box.

17. When all heater tapes have been attached and connected, position the fryer near the hood, apply power and test to ensure the heater tapes are functioning.





18. Replace back on fryer.

Continued on the next page.



Fig 12 Wago connectors shown in junction box.

Continued from page 3

19. Once fryer has powered up, wait one (1) additional minute with the controller OFF and press the **HOME** button on the left controller. 
20. Press the **SETTINGS** button. 
21. Press the **SERVICE** button. 
22. Enter **3000**.
23. Press the √ (check) button.
24. Press the down arrow button two times.
25. Press **AUTO TOP OFF VAT**.
26. Press **OFF**.
27. Press the **HOME** button to exit. 
28. Repeat steps 19—27 on each controller.
29. Press and HOLD the momentary reset switch located close to the USB port. Ensure the switch is pressed and held for one (1) minute.

Continued on the next page.

Using Wago Connectors

Wago connectors allow stripped wires (3mm) to be cleanly connected. They are easy to use:

1. Lift completely the orange lever. It will stay upright.
2. Insert stripped wires.
3. Close orange levers.

